



Tuning Fork Level Switch



Sensorsystem®
Innovative Sensors & Controls for Automation

PRODUCT INTRODUCTION

WORKING PRINCIPLE

The piezoelectric component is used to drive the tuning fork and feedback signal, which produces the resonance on the fork. When the fork comes into contact with a material, the fork will release some frequency signal as feedback. It will be converted into the output of the contact signal when the circuit detects the frequency decrease of the signal.

The product relies on the damping effect by covering the testing material on the tuning fork which reduces the vibration frequency of the tuning fork and outputs a switch signal. Therefore, there is no signal amplification circuit inside, which can eliminate the trouble of frequent sensitivity adjustment due to the material change.

FEATURE

- SPDT Relay output, SSR MOSFET output.
- Wide voltage supply range 20~250 Vac/Vdc,50/60Hz
- No frequent calibration required, easy-to-use, sturdy and durable design. High/low failure safe mode, safe and reliable.
- Sensitivity adjustment is available for different densities of media. Fine powder can be detected.
- Suitable for liquid, powder, and solid application.
- Dual insulation can reduce damage on the PCB board caused by great changes in temperature and humidity, as well as condensation effects (SC3□ series).
- It can be tested by pressing the test button after installation (SC3□ series).
- Output switch delay function (SC3□ series).
- Self-diagnosis mechanism can detect the abnormality such as the abrasion of the tuning fork or the material viscosity (SC3□ series).
- The compact built-in wiring box can save the installation space (SC3□ series).
- The wiring box can rotate 270 degrees, facilitating adjustment of the inlet direction (SC3□ series).
- The minimum measurable specific gravity can reach 0.01 g/cm³ (SC35 series).
- Ultra protection mechanism can set the secondary output contact point as alarm output (SC35 series).
- Support the function of detecting underwater sediments (SC35 series).
- All-in-one design, 3/4" (SC38 series) 、 1" (SC39 series) thread is suitable for the installation of a small tube.
- Adjustment setting for different densities of media $\rho > 0.5 \text{ g/cm}^3$ or $\rho < 0.7 \text{ g/cm}^3$ (SC38 & 39 series).
- Switch delay setting function (SC3□ series).
- Alarm indicators based on failure status or output status selected according to the customer's habits (SC3□ series).
- Automatic calibration of the operation points for different densities of media as required by the customer (SC38 & 39 series).

APPLICABLE MATERIALS

The tuning fork level switch can be widely applied to detect the min. and max. level in tanks, silos and hoppers filled with materials of different densities and state. The following list shows its applications.

POWDER

- | | |
|------------------------|------------------------|
| 1. Powdered milk | 15. Pellets |
| 2. Frozen potato chips | 16. Peanuts |
| 3. Beans | 17. Tobacco |
| 4. Sugar | 18. Wood shavings |
| 5. Sweets | 19. Chalk |
| 6. Coffee beans | 20. Stearin chips |
| 7. Coffee powder | 21. Powdered cellulose |
| 8. Frozen dry coffee | 22. Glass fine power |
| 9. Tea | 23. Granular plastics |
| 10. Salt | 24. Gravel |
| 11. Flour | 25. Powdered clay |
| 12. Foundry sand | 26. Polystyrene powder |
| 13. Spices | 27. Styrofoam |
| 14. Animal food | 28. Soda |

LIQUID

1. Water & Solutions
2. General Purpose Solvent
3. Soy sauce
4. Heavy oil
5. Petroleum
6. Oil
7. Ink
8. Cream
9. Drink & Beverage
10. Corrosive liquid

APPLICATION SCOPE

It is applicable to the max. and min. level detection of the tanks or tubes filled with various solid/liquid media. The product has a variety of applications, such as in the chemical fiber industry, rubber industry, tire industry, cement industry, steel industry, food industry, pharmaceutical industry, and animal feed factories in terms of the level detection for the bins of the raw material/process/finished products.

LITE-TYPE

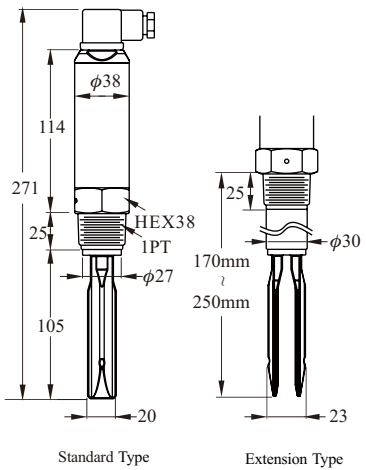
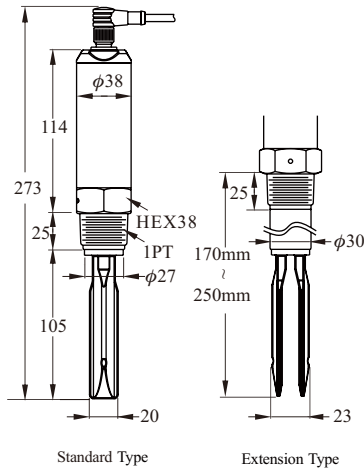
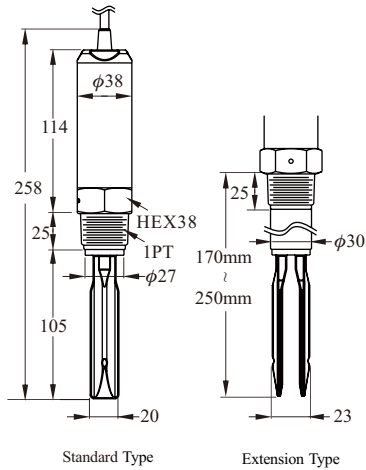
<p>Dimensions (Unit:mm)</p>			
<p>Model no.</p>	<p>SC2400/2410 【DIN Connector】</p>	<p>SC2400/2410 【M12 Connector】</p>	<p>SC2400/2410 【Cable Wire Type】</p>
<p>Supply voltage & output</p>	<p>SC240 □□:20~250Vac / Vdc 2 wire Contactless electronic switch. SC241□□:12~55 Vdc 3 wire PNP/ NPN Output.</p>		
<p>Fork length</p>	<p>100mm</p>		
<p>Ambient temp.</p>	<p>-40~80°C</p>		
<p>Ambient humidity</p>	<p>80% RH non-condensed</p>		
<p>Storage temp.</p>	<p>-40~85°C</p>		
<p>Process temp.</p>	<p>SC24□□□T: -40~+150°C SC24□□□: -40~+100°C</p>		
<p>Process pressure</p>	<p>Maximum 40 Bar</p>		
<p>Min. material density sensed</p>	<p>Solid:density: $\geq 0.07\text{g/cm}^3$ Liquid:density: $\geq 0.7\text{g/cm}^3$ Viscosity: 1~10000 cSt</p>		
<p>Magnetic testing</p>	<p>Output function test performed by putting magnets near the indicated spot</p>		
<p>Vibrating frequency</p>	<p>350~370Hz</p>		
<p>Status indication</p>	<p>Green light:indicate power supply Red light:indicate operating mode</p>		
<p>Housing material</p>	<p>SUS304</p>		
<p>Fork material</p>	<p>SUS304, SUS316, SUS316L</p>		
<p>IP protection</p>	<p>IP65</p>	<p>IP67</p>	<p>IP67</p>
<p>Mounting</p>	<p>1" more</p>		
<p>Conduit</p>	<p>Valve plug DIN 43650</p>	<p>M12x1 Connector(180° / 90°)</p>	<p>Cable connector</p>

MINI-TYPE

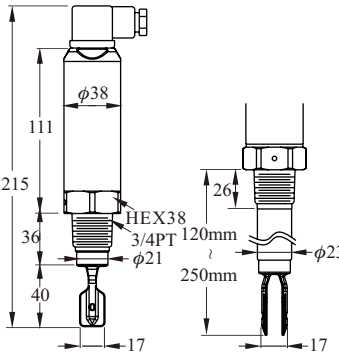
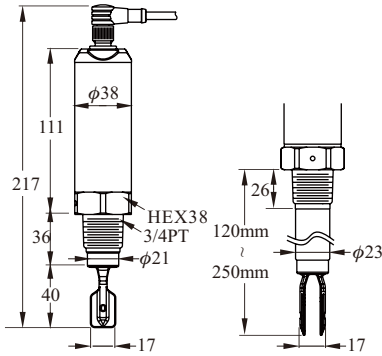
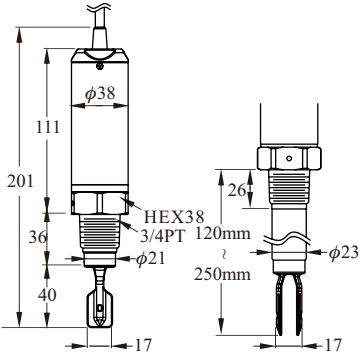
<p>Dimensions (Unit:mm)</p>	 <p>Standard Type Extension Type</p>	 <p>Standard Type Extension Type</p>	 <p>Standard Type Extension Type</p>
<p>Model no.</p>	<p>SC2800/2810 【DIN Connector】</p>	<p>SC2800/2810 【M12 Connector】</p>	<p>SC2800/2810 【Cable Wire Type】</p>
<p>Supply voltage & output</p>	<p>SC280□:20~250,50/60Hz Vac/Vdc 2 wire Contactless electronic switch. SC281□:12~55 Vdc 3 wire PNP/ NPN Output</p>		
<p>Fork length</p>	<p>40mm</p>		
<p>Ambient temp.</p>	<p>-40°C~80°C</p>		
<p>Ambient humidity</p>	<p>80% RH non-condensed</p>		
<p>Storage temp.</p>	<p>-40°C~85°C</p>		
<p>Process temp.</p>	<p>SC28□□□: -40°C~100°C SC28□□□T: -40°C~150°C</p>		
<p>Process pressure</p>	<p>-1~600PSI (40BAR)</p>		
<p>Min. material density sensed</p>	<p>Liquid:density: $\geq 0.7\text{g/cm}^3$ Viscosity: 1~10000 cSt</p>		
<p>Magnetic testing</p>	<p>Output function test performed by putting magnets near the indicated spot</p>		
<p>Vibrating frequency</p>	<p>1 KHz \pm 10%</p>		
<p>Status indication</p>	<p>Green light:indicate power supply Red light:indicate operating mode</p>		
<p>Housing material</p>	<p>SUS304</p>		
<p>Fork material</p>	<p>SUS304, SUS316, SUS316L</p>		
<p>IP protection</p>	<p>IP65</p>	<p>IP67</p>	<p>IP67</p>
<p>Mounting</p>	<p>3/4"more</p>		
<p>Conduit</p>	<p>Valve plug DIN 43650</p>	<p>M12x1 Connector(180° / 90°)</p>	<p>Cable connector</p>



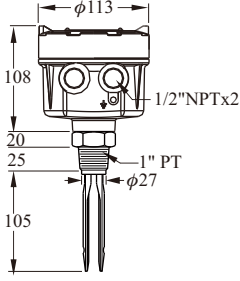
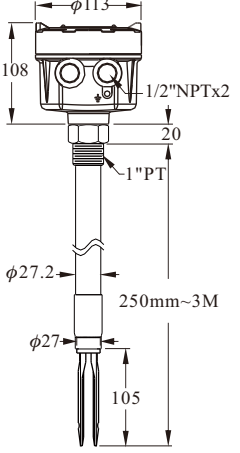
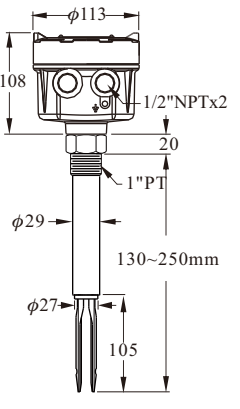

STANDARD TYPE

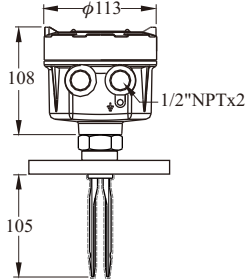
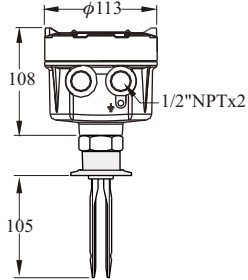
<p>Dimensions (Unit:mm)</p>			
<p>Model No.</p>	<p>SC1400 【 Standard Type 】</p>	<p>SC1410 【 Tuning Fork Ultra Extension Type 】</p>	<p>SC1420 【 Tuning Fork Extension Type 】</p>
<p>Level sensor housing</p>	<p>Aluminum / IP65</p>		
<p>Probe construction</p>	<p>SUS 304 / 316 / 316L</p>		
<p>Mounting</p>	<p>1"PT</p>		
<p>Conduit</p>	<p>1/2"NPT×2</p>		
<p>Max. vertical load on rod.</p>	<p>177in.Lbs(20Nm)</p>		
<p>Process pressure.</p>	<p>-1~600PSI (40BAR)</p>		
<p>Power supply</p>	<p>20~250Vac/Vdc,50/60Hz</p>		
<p>Power consumption</p>	<p>10VA</p>		
<p>Ambient temp.</p>	<p>-40°C~60°C</p>		
<p>Process temp.</p>	<p>-40°C~130°C</p>		
<p>Signal output</p>	<p>Relay, SPDT, 5A/250Vac/ 28Vdc, 1 set or 2 set SSR(MOSFET) 400mA/60 Vac/ Vdc, 1 set or 2 set</p>		
<p>Min. material density sensed</p>	<p>Solid:≥0.07g/cm³, Liquid: ≥0.7g/cm³</p>		
<p>Time delay</p>	<p>0.6 Second / Operate; 1~3 Seconds / Reset</p>		
<p>Vibrating frequency.</p>	<p>350~370Hz</p>		
<p>Selectable Fail-safe</p>	<p>Hi./ Lo.</p>		
<p>Selectable sensitivity</p>	<p>Hi./ Lo.</p>		

STANDARD TYPE

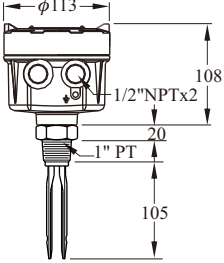
Dimensions (Unit:mm)		
Model No.	SC1540 【 Corrosion Proof Type 】	SC1600 【 Sanitary Type 】
Level sensor housing	Aluminum / IP65	
Probe construction	316L Coating TEFLON	316L
Mounting	1" Flange (min.)	2" Sanitary
Conduit	1/2"NPT×2	
Max. vertical load on rod.	177in.Lbs(20Nm)	
Process pressure.	-1~600PSI (40BAR)	
Power supply	20~250Vac/dc, 50/60Hz	
Power Consumption	10VA	
Ambient temp.	-40°C~60°C	
Process temp.	-40°C~130°C	
Signal output	Relay, SPDT, 5A/250Vac/ 28Vdc, 1 set or 2 set SSR(MOSFET) 400mA/60 Vac/ Vdc, 1 set or 2 set	
Min. material density sensed	Solid: $\geq 0.07\text{g/cm}^3$, Liquid: $\geq 0.7\text{g/cm}^3$	
Time delay	0.6 Second / Operate; 1~3 Seconds / Reset	
Vibrating frequency.	350~370Hz	
Selectable Fail-safe	Hi./ Lo.	
Selectable sensitivity	Hi./ Lo.	

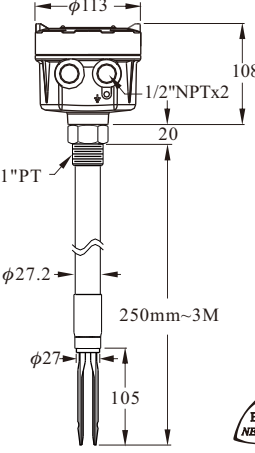
EX-PROOF TYPE

<p>Dimensions (Unit:mm)</p>	 <p style="text-align: center;">   </p>	 <p style="text-align: center;">   </p>
<p>Model No.</p>	<p>SC1740 【 Standard Type 】</p>	<p>SC1741 【 Tuning Fork Ultra Extension Type 】</p>
<p>Level sensor housing</p>	<p>Aluminum</p>	
<p>Probe construction</p>	<p>SUS 304 / 316 / 316L</p>	
<p>Mounting</p>	<p>1"PT</p>	<p>1"PT</p>
<p>Conduit</p>	<p>1/2"NPT×2</p>	
<p>Max. vertical load on rod.</p>	<p>177in.Lbs(20Nm)</p>	
<p>Process pressure.</p>	<p>-1~600PSI (40BAR)</p>	
<p>Power supply</p>	<p>20~250,50/60Hz Vac/Vdc</p>	
<p>Power consumption</p>	<p>10VA</p>	
<p>Ambient temp.</p>	<p>-20°C~70°C</p>	
<p>Process temp.</p>	<p>-40°C~130°C</p>	
<p>Signal output</p>	<p>Relay, SPDT, 3A/250Vac/ 28Vdc, 1 set or 2 set SSR(MOSFET) 400mA/60 Vac/ Vdc, 1 set or 2 set</p>	
<p>Min. material density sensed</p>	<p>Solid: ≥0.07g/cm³, Liquid: ≥0.7g/cm³, viscosity : 1~10000 cst</p>	
<p>Time delay</p>	<p>0.6 Second / Operate; 1~3 Seconds / Reset</p>	
<p>Vibrating frequency.</p>	<p>350~370Hz</p>	
<p>Selectable Fail-safe</p>	<p>Hi./ Lo.</p>	
<p>Selectable sensitivity</p>	<p>Hi./ Lo.</p>	

SC35 TUNING FORK LEVEL SWITCH

NEPSI PROOF No.GYJ14.1150
DIP A20/21 T_A,T₂~T₆ IP66/67

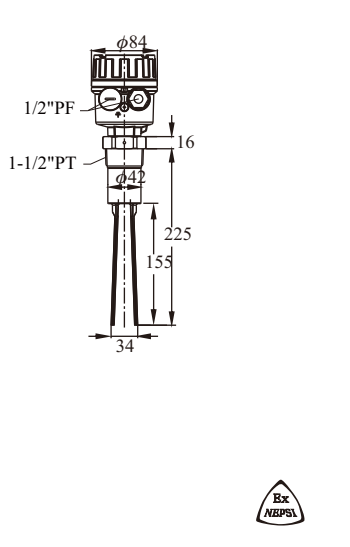
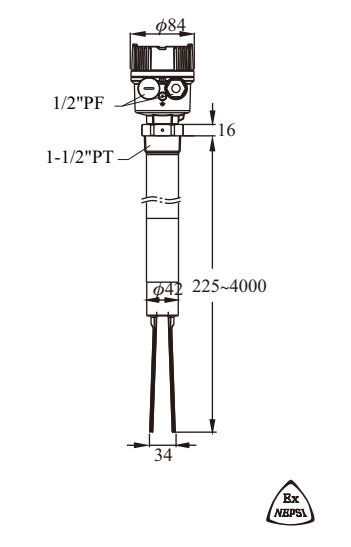
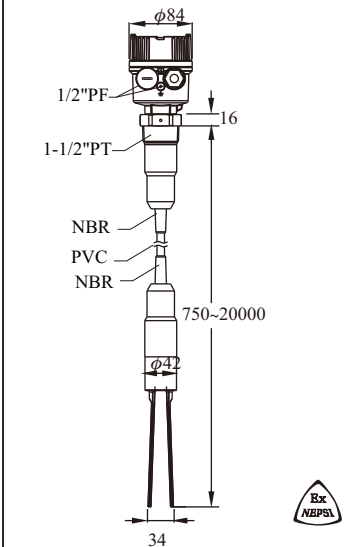
Dimensions (Unit:mm)			
Model No.	SC350 【Standard Type】	SC351 【Extension Type】	SC352 【Cable Type】
Level sensor housing	Built-in box, aluminum coating IP66/IP67		
Power supply	19 ~253 Vdc / Vac, 50/60 Hz ; NPN / PNP(10~55Vdc)		
Probe construction	Max. 1.5 W		
Voltage endurance capability	3.7 kV		
Overvoltage protection	overvoltage category II		
Storage temp.	-40~85 °C		
Ambient temp.	-40~85 °C		-40~75 °C
Process temp.	-40~150 °C	-40~150 °C	-40~80 °C
Material density	≥ 0.01 g/cm ³ or ≥ 0.05 g/cm ³		
Measuring frequency	140 Hz ± 5 Hz		
Material dimension	Max.10 mm		
Conduit	1/2"PF / 1/2"NPT(Ex-proof type only supports 1/2"NPT)		
External diameter of cable applicable to conduit	φ6~φ10 mm		
Pressure resistance	Max.25 Bar		Max. 2 Bar
Output signal	2 sets of SPDT relay output/2 sets of transistor output / 3 wires NPN/PNP transistor output		
Contact capacity	Relay: 6A / 250Vac , 6A / 28Vdc ; Transistor: 350mA , 60Vac / Vdc NPN / PNP / Transistor: 350mA , 55Vdc		
Ex-proof certification	Dust ex-proof (DIP A20/21 T _A , T ₂ ~T ₆ IP66/67, optional)		

SC35 TUNING FORK LEVEL SWITCH

NEPSI PROOF No.GYJ14.1150
DIP A20/21 T_A, T₂~T₆ IP66/67

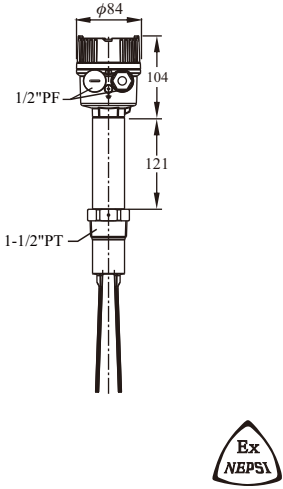
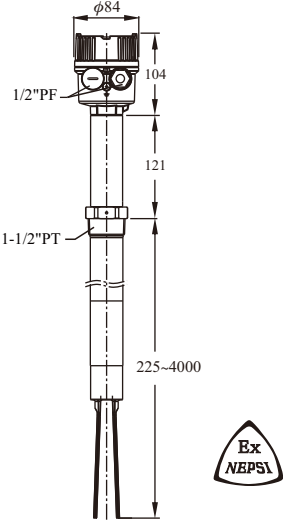
Dimensions (Unit:mm)		
Model No.	SC350 [High-temp. Type]	SC351 [High-temp. Extension Type]
Level sensor housing	Built-in box, aluminum coating IP66/IP67	
Power supply	19 ~253 Vdc / Vac, 50/60 Hz	
Probe construction	Max. 1.5 W	
Voltage endurance capability	3.7 kV	
Overvoltage protection	overvoltage category II	
Storage temp.	-40~85 °C	
Ambient temp.	-40~85 °C	
Process temp.	-40~280 °C	
Material density	$\geq 0.01 \text{ g/cm}^3$ or $\geq 0.05 \text{ g/cm}^3$	
Measuring frequency	140 Hz \pm 5 Hz	
Material dimension	Max.10 mm	
Conduit	1/2"PF / 1/2"NPT(Ex-proof type only supports 1/2"NPT)	
External diameter of cable applicable to conduit	$\phi 6 \sim \phi 10 \text{ mm}$	
Pressure resistance	Max. 25 Bar	
Output signal	2 sets of SPDT relay output/2 sets of transistor output	
Contact capacity	Relay: 6A / 250Vac , 6A / 28Vdc Transistor: 350mA , 60Vac / Vdc	
Ex-proof certification	Dust ex-proof (DIP A20/21 T _A , T ₂ ~T ₆ IP66/67, optional)	

SC38 MULTI-FUNCTIONAL TUNING FORK LEVEL SWITCH

NEPSI PROOF No.GYB14.1796X
Ex ia IIC T3-T6 Ga

※ Output type is 8/16mA current output type has certified by NEPSI.

Dimensions (Unit:mm)			
	SC380 【Standard Type】	SC381 【Extension Type】	SC382 【Ultra Extension Type】
Output type	8/16mA output type	3 wires (NPN/PNP) output type	Dual-relay output type
Working voltage	11 ~36 Vdc	10 ~55 Vdc	19~253Vac/dc,50/60Hz
Power consumption	< 600mW	< 830mW	Max. 1.3W
Input protection	Reversed power supply protection function		NA
Overvoltage protection	overvoltage category III		
Measuring error	Max.±1mm		
Repeatability	0.5mm		
Hysteresis band	Approx.2mm		
Storage temp.	-40~85 °C		
Ambient temp.	-40~85 °C (Intrinsically safe type-40~70 °C)	-40~85 °C(Refernce operation manual)	
Process temp.	-40~150 °C (Refernce operation manual)		
Applicable density liquid	≥0.5 g/cm ³ or ≥0.7 g/cm ³		
Liquid viscosity	Max.10000mm ² / S(10000cst)		
Granule size contained in the liquid	Max.φ5 mm		
External diameter of cable applicable to conduit	φ6~φ10 mm		
Pressure resistance	Max.40 Bar		
Output signal	Intrinsically safe signal 8/16mA	Transistor output (NPN/PNP)	2 sets of SPDT relay output
Contact capacity	NA	350mA , 55Vdc	6A / 250Vac , 6A / 28Vdc
Protection level	IP66/67		
Intrinsically safe parameters	Ui(V)=36V , Ii=100mA, Pi=1W Ci(nF)=0 , Li(uH)=0	NA	NA

※It shall combine with the ex-proof fence meeting level Ex ia to form the intrinsically safe system. Please refer to page 28 for more details.

SC38 MULTI-FUNCTIONAL TUNING FORK LEVEL SWITCH

NEPSI PROOF No.GYB14.1796X
Ex ia IIC T3-T6 Ga

※ Output type is 8/16mA current output type has certified by NEPSI.

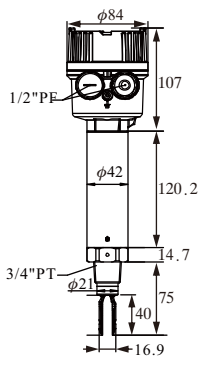
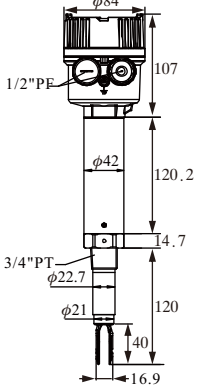
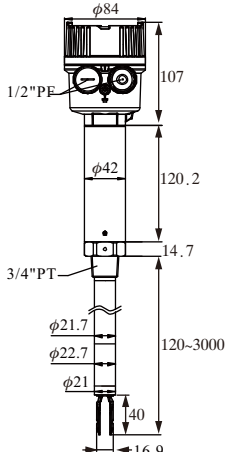
Dimensions (Unit:mm)	 <p style="text-align: center;">SC380 【High-temp. Type】</p>	 <p style="text-align: center;">SC381 【High-temp. Extension Type】</p>	 <p style="text-align: center;">SC382 【High-temp. Extension Type】</p>
Output type	8/16mA output type	3 wires (NPN/PNP) output type	Dual-relay output type
Working voltage	11 ~36 Vdc	10 ~55 Vdc	19~253Vac/dc,50/60Hz
Power consumption	< 600mW	< 830mW	Max. 1.3W
Input protection	Reversed power supply protection function		NA
Overvoltage protection	overvoltage category III		
Measuring error	Max.±1mm		
Repeatability	0.5mm		
Hysteresis band	Approx.2mm		
Storage temp.	-40~85 °C		
Ambient temp.	-40~85 °C(Refernce operation manual)		
Process temp.	-40~150 °C		
Applicable density liquid	≥0.5 g/cm ³ or ≥0.7 g/cm ³		
Liquid viscosity	Max.10000mm ² / S(10000cst)		
Granule size contained in the liquid	Max.φ5 mm		
External diameter of cable applicable to conduit	φ6~φ10 mm		
Pressure resistance	Max.40 Bar		
Output signal	Intrinsically safe signal 8/16mA	Transistor output (NPN/PNP)	2 sets of SPDT relay output
Contact capacity	NA	350mA , 55Vdc	6A / 250Vac , 6A / 28Vdc
Protection level	IP66/67		
Intrinsically safe parameters	Ui(V)=36V , li=100mA,Pi=1W Ci(nF)=0 , Li(uH)=0	NA	NA

※It shall combine with the ex-proof fence meeting level Ex ia to form the intrinsically safe system. Please refer to page 28 for more details.

SC39 MULTI-FUNCTIONAL TUNING FORK LEVEL SWITCH

Dimensions (Unit:mm)	SC390 Standard Type		SC391 Extension Type	
Output type	8/16mA output type	3 wires (NPN/PNP) output type	Dual-relay output type	Dual-MOSFET output type
Working voltage	11 ~36 Vdc	10 ~55Vdc	19 ~253Vac/dc, 50/60Hz	19 ~253Vac/dc, 50/60Hz
Power consumption	< 600mW	< 830mW	Max. 1.3W	Max. 1.3W
Input protection	Reversed power supply protection function		NA	NA
Overtoltage protection	overtoltage category III			
Hysteresis band	Approx.5mm			
Ambient temp.	-40~85 °C (Refernce operation manual)			
Process temp.	-40~150 °C (Refernce operation manual)			
Applicable density liquid	$\geq 0.5 \text{ g/cm}^3$ or $\geq 0.7 \text{ g/cm}^3$			
Liquid viscosity	Max.10000mm ² / S(10000cst)			
External diameter of cable applicable to conduit	$\phi 6 \sim \phi 10 \text{ mm}$			
Pressure resistance	Max.60Bar			
Output signal	Intrinsically safe signal 8 / 16mA	Transistor output NPN / PNP	2 sets of SPDT relay output	MOSFET SPST×2
Contact capacity	NA	350mA · 55Vdc	6A/250Vac/28Vdc	350mA · 60Vac/dc
Protection level	IP66/67			

SC39 MULTI-FUNCTIONAL TUNING FORK LEVEL SWITCH

Dimensions (Unit:mm)	SC390 High-temp. Type	SC391 High-temp. Extension Type

Output type	8/16mA output type	3 wires (NPN/PNP) output type	Dual-relay output type	Dual-MOSFET output type
Working voltage	11 ~36 Vdc	10 ~55Vdc	19 ~253Vac/dc, 50/60Hz	19 ~253Vac/dc, 50/60Hz
Power consumption	< 600mW	< 830mW	Max. 1.3W	Max. 1.3W
Input protection	Reversed power supply protection function		NA	
Overvoltage protection	overvoltage category III			
Hysteresis band	Approx.5mm			
Ambient temp.	-40~85 °C (Refernce operation manual)			
Process temp.	-40~150 °C			
Applicable density liquid	$\geq 0.5 \text{ g/cm}^3$ or $\geq 0.7 \text{ g/cm}^3$			
Liquid viscosity	Max.10000mm ² / S(10000cst)			
External diameter of cable applicable to conduit	$\phi 6 \sim \phi 10 \text{ mm}$			
Pressure resistance	Max.60Bar			
Output signal	Intrinsically safe signal 8 / 16mA	Transistor output NPN / PNP	2 sets of SPDT relay output	MOSFET SPST×2
Contact capacity	NA	350mA · 55Vdc	6A/250Vac/28Vdc	350mA · 60Vac/dc
Protection level	IP66/67			

WIRING INSTRUCTIONS (STANDARD TYPE)

SC1400X, SC1410X, SC1420X, SC1540X, SC1600X, SC1740X, SC1741X

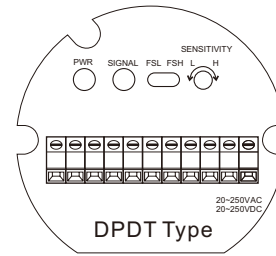
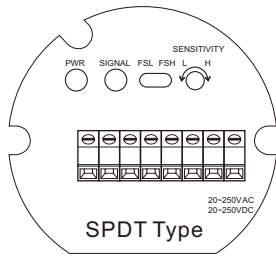

Relay output type(SPDT) SSR(MOSFET) output type

Relay output type (DPDT)

SSR(MOSFET) output type

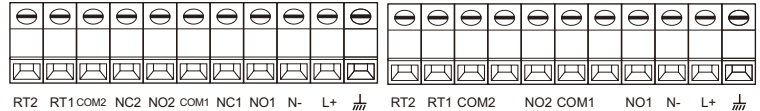
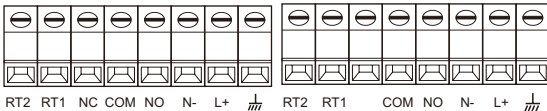

FUNCTIONAL DESCRIPTION

Description of terminal functions

- L+, N-: Power Supply
- NC, COM, NO: Relay Output
- RT1, RT2: Remote-Test
- \perp : Ground Connection
- COM1, NO1 : SSR(MOSFET) Output
- COM2, NO2 : The second set of SSR (MOSFET) output (Optional)

DESCRIPTION OF PANEL FUNCTIONS

- PWR: Power Supply (Green Light)
- SIGNAL: Output Indication (Red Light)
- FSH: Power On. The signal lamp is on and the relay is conductive. While the tuning fork switch senses the material, the signal lamp is off and relay is not conductive.
- FSL: Power On. The signal lamp is off and the relay is not conductive. While the tuning fork switch senses the material, the signal lamp is on and relay is conductive.
- SENSITIVITY L: Low Sensitivity
- SENSITIVITY H: High Sensitivity

FAIL-SAFE HIGH / LOW PROTECTION

FSH (Fail-Safe High) Protection:

Switch to FSH mode.

Normal Status: The signal lamp is on. It indicates that the tuning fork switch does not sense the material and the relay is conductive.

Failure: When the power shuts down, the signal lamp is off. It indicates that the tuning fork switch is voided and the relay is not conductive.

FSL (Fail-Safe Low) Protection:

Switch to FSL mode.

Normal Status: The signal lamp is on.

The tuning fork switch senses the material and the relay is conductive.

Failure: When the power shuts down, the signal lamp is off. The tuning fork switch is voided and the relay is not conductive.

SENSITIVITY ADJUSTMENT

The SENSITIVITY is located on the right side of the panel. The user is able to do the minor adjustment by the screw driver when it rotates for 22 turns. If it turns to H position clockwise, the sensitivity increases; if it turns to L position anti-clockwise, the sensitivity decreases. The sensitivity is originally set at max. value. The switching point is at 15mm from the tip of the tuning fork. The switching point position will be changed by the sensitivity value. If the sensitivity adjusts to lower value, the switching point position is moving backward; if the sensitivity adjusts to high value, the switching point position is moving forward. User may change the switching point position by adjusting the sensitivity. The changing range of switching point is about 60mm. For example, if the switching point needs to be moved backward by 30mm, the user needs to adjust SENSITIVITY anti-clockwise by 10 turns. In general cases, there is no need for sensitivity adjustment.

	FSL		FSH	
Level				
Contact form	NO COM NC	NO COM NC	NO COM NC	NO COM NC
Indication	○	☀	☀	○
Status	Fail	Normal	Normal	Fail

WIRING INSTRUCTIONS (LITE-TYPE/MINI-TYPE)

SC240X/SC280(Two wires) WIRING

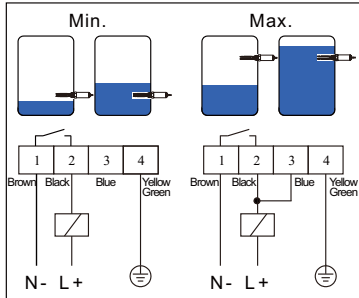
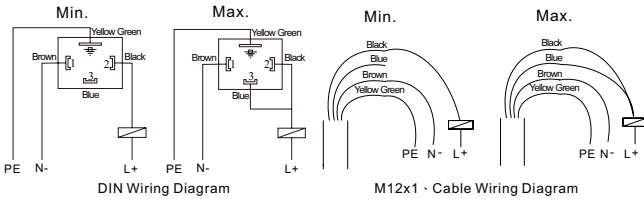

Figure 1 Two wires wiring



Wiring

Power can be AC/DC switching. Two wires are connected with terminals (L+/N-) as in Figure 1.

Low (Min.) Mode:

Pin 1 (Brown) is connected to N-. Pin 2 (Black) is connected to L+ with relay. Pin 4 (Yellow Green) connects to tank ground.

High (Max.) mode:

Pin 1 (Brown) is connected to N-. Pin 3 is connected to pin 2 (Black) to L+ with Relay. Pin 4 (Yellow Green) connects to tank ground.

SC241X/SC281(Three wires) WIRING

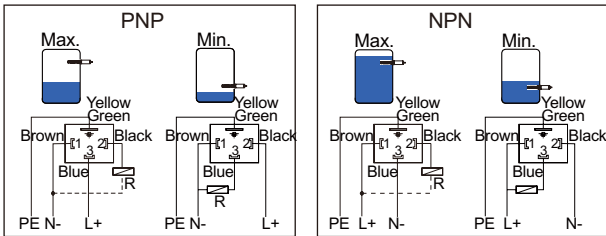

DIN Wiring Diagram

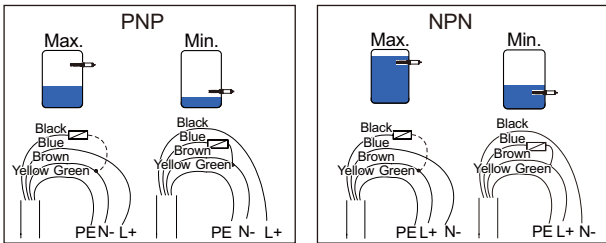

M12x1 Cable Wiring Diagram

Figure 2 PNP / NPN Output Wiring Diagram

Wiring

Power supply is for DC only. Output is PNP / NPN. Please see Figure 2.

PNP wiring :

High(Max.) Mode:

Pin 1(Brown) connects to N-. Pin 3 (Blue) connects to L+. To output, it is pin 2. (Black) connects to N- with relay. Pin 4 (Yellow Green) connects to tank ground.

Low(Min.)Mode:

Pin 1 (Brown) connects to N-. Pin 2 (Black) connects to L+. To output, Pin 3 (Blue) connects to N- with relay. Pin 4 (Yellow Green) should contact to tank ground.

NPN wiring :

High(Max.) Mode:

Pin 1 (Brown) connects to L+. Pin 3 (Blue) connects to N-. To output, Pin 2 (Black) connects to L+ with relay. Pin 4 (Yellow Green) should contact to tank ground.

Low(Min.)Mode:

Pin1 (Brown) connects to L+. Pin 2 (Black) connects to N-. To output Pin 3 (Blue) connects to L+ with relay. Pin 4 (Yellow Green) should contact to tank ground.

WIRING INSTRUCTIONS (SC35)

WIRING CONFIGURATION DIAGRAM AND INTRODUCTION OF FEATURES

Dual-relay output

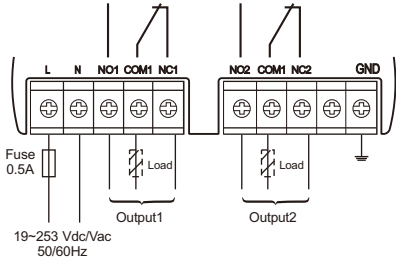

Load: External load
 $U \sim \text{max. } 250\text{Vac}@I_L \sim \text{max. } 6\text{A}$
 $U = \text{max. } 28\text{Vdc}@I_L = \text{max. } 6\text{A}$

Failure mode	Material level	Output signal			LED indicators		
		output1	output2		Power	Status	Alarm
			S.S. OFF	S.S. ON	Green	Yellow	Red
MAX						$\text{o.s.} \begin{matrix} \text{ON} \\ \text{OFF} \end{matrix}$	
						$\text{o.s.} \begin{matrix} \text{OFF} \\ \text{ON} \end{matrix}$	
MIN						$\text{o.s.} \begin{matrix} \text{ON} \\ \text{OFF} \end{matrix}$	
						$\text{o.s.} \begin{matrix} \text{OFF} \\ \text{ON} \end{matrix}$	
Viscous material		Maintain the previous state				$\text{o.s.} \begin{matrix} \text{OFF} \\ \text{ON} \end{matrix}$	
Wear of tuning fork							

Dual-transistor output

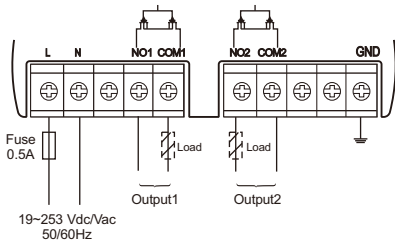

Load: External load
 $U \sim \text{max. } 60\text{Vac}@I_L \sim \text{max. } 350\text{mA}$
 $U = \text{max. } 60\text{Vdc}@I_L = \text{max. } 350\text{mA}$
 ※ External load R must be connected

Failure mode	Material level	Output signal			LED indicators		
		output1	output2		Power	Status	Alarm
			S.S. OFF	S.S. ON	Green	Yellow	Red
MAX		$\square \xrightarrow{I_L} \square$	$\square \xrightarrow{I_L} \square$	$\square \xrightarrow{I_L} \square$		$\text{o.s.} \begin{matrix} \text{ON} \\ \text{OFF} \end{matrix}$	
		$\square \xrightarrow{<100\mu\text{A}} \square$	$\square \xrightarrow{<100\mu\text{A}} \square$	$\square \xrightarrow{I_L} \square$		$\text{o.s.} \begin{matrix} \text{OFF} \\ \text{ON} \end{matrix}$	
MIN		$\square \xrightarrow{I_L} \square$	$\square \xrightarrow{I_L} \square$	$\square \xrightarrow{I_L} \square$		$\text{o.s.} \begin{matrix} \text{ON} \\ \text{OFF} \end{matrix}$	
		$\square \xrightarrow{<100\mu\text{A}} \square$	$\square \xrightarrow{<100\mu\text{A}} \square$	$\square \xrightarrow{I_L} \square$		$\text{o.s.} \begin{matrix} \text{OFF} \\ \text{ON} \end{matrix}$	
Viscous material		Maintain the previous state		$\square \xrightarrow{<100\mu\text{A}} \square$		$\text{o.s.} \begin{matrix} \text{OFF} \\ \text{ON} \end{matrix}$	
Wear of tuning fork		$\square \xrightarrow{<100\mu\text{A}} \square$	$\square \xrightarrow{<100\mu\text{A}} \square$	$\square \xrightarrow{<100\mu\text{A}} \square$			
Output1>350mA		$\square \xrightarrow{<100\mu\text{A}} \square$	Maintain the previous state	$\square \xrightarrow{<100\mu\text{A}} \square$			
Output2>350mA		Maintain the previous state	$\square \xrightarrow{<100\mu\text{A}} \square$	$\square \xrightarrow{<100\mu\text{A}} \square$			
Output1 & Output2>350mA		$\square \xrightarrow{<100\mu\text{A}} \square$	$\square \xrightarrow{<100\mu\text{A}} \square$	$\square \xrightarrow{<100\mu\text{A}} \square$			

※ When output is off, there will be no error current status

: ON : Flash : OFF

: Relay ON : Relay OFF I_L : Load current

WIRING INSTRUCTIONS (SC38 & SC39)

WIRING CONFIGURATION DIAGRAM AND INTRODUCTION OF FEATURES

8/16mA output

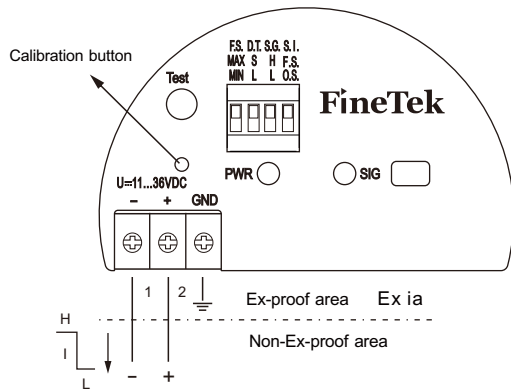

PNP/NPN Output

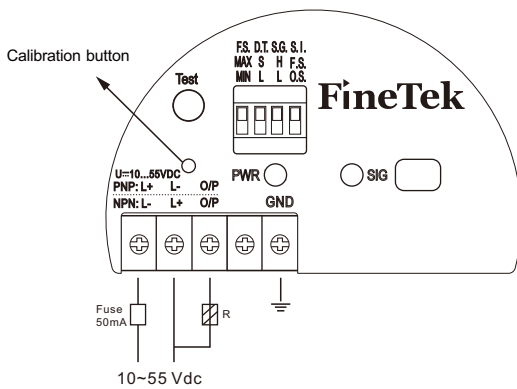

Dual Relay output

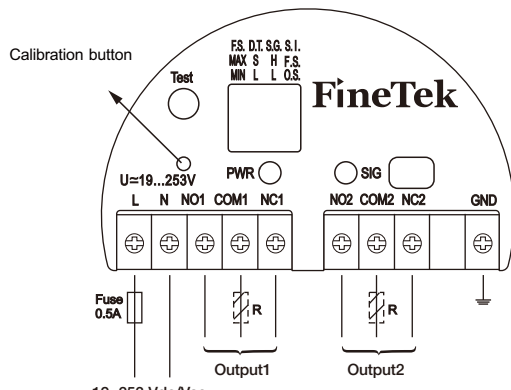

Failure mode	Material level	Output signal	LED indicators
MAX		+ 2 → ~16mA → 1	☀ O.S. ☀ F.S. ○
		+ 2 → ~8mA → 1	☀ O.S. ○ F.S. ☀
MIN		+ 2 → ~16mA → 1	☀ O.S. ☀ F.S. ○
		+ 2 → ~8mA → 1	☀ O.S. ○ F.S. ☀
Instrument failure		+ 2 → <3.6mA → 1	☀ ☀

~16mA=16mA ±5%
~8mA=8mA ±5%

☀ : ON ☀ : Flash ○ : OFF

Failure mode	Material level	Output signal	LED indicators
MAX		□ → I _L → □	☀ O.S. ☀ F.S. ○
		□ → <100μA → □	☀ O.S. ○ F.S. ☀
MIN		□ → I _L → □	☀ O.S. ☀ F.S. ○
		□ → <100μA → □	☀ O.S. ○ F.S. ☀
Instrument failure		□ → <100μA → □	☀ ☀
Over Load(I _L >350mA)		□ → <100μA → □	☀ ☀

I_L : Load current

☀ : ON ☀ : Flash ○ : OFF

R : External load
U = max. 55Vdc@I_L = max. 350mA

Failure mode	Material level	Output signal	LED indicators	
			PWR	SIG
MAX			☀ O.S. ☀ F.S. ○	
			☀ O.S. ○ F.S. ☀	
MIN			☀ O.S. ☀ F.S. ○	
			☀ O.S. ○ F.S. ☀	
Instrument failure			☀	☀

R: External load
U ~ max. 250Vac@I_L ~ max. 6A
U = max. 28Vdc@I_L = max. 6A

☀ : ON ☀ : Flash ○ : OFF

WIRING INSTRUCTIONS (SC38 & SC39)

Dual MOSFET Output (SC39 only)

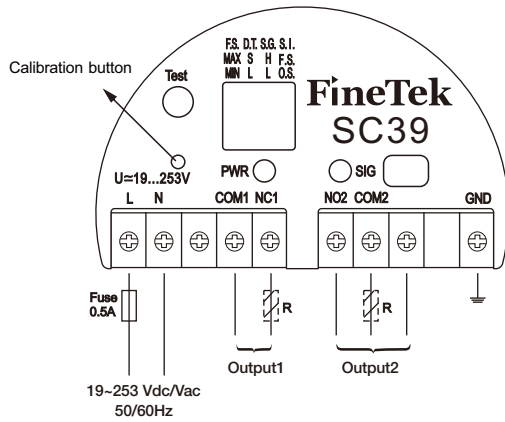

19~253 Vdc/Vac
50/60Hz

Load: External load
 $U \sim \text{max. } 60\text{Vac} @ I_L \sim \text{max. } 350\text{mA}$
 $U = \text{max. } 60\text{Vdc} @ I_L = \text{max. } 350\text{mA}$
 ※ External load R must be connected

Failure mode	Material level	Output signal	LED indicators						
MAX		NO1 $\xrightarrow{I_L}$ COM1 NO2 $\xrightarrow{I_L}$ COM2	<table border="0"> <tr><td>☀</td><td>O.S.</td><td>☀</td></tr> <tr><td>F.S.</td><td>○</td><td></td></tr> </table>	☀	O.S.	☀	F.S.	○	
	☀	O.S.	☀						
F.S.	○								
	NO1 $\xrightarrow{<100\text{mA}}$ COM1 NO2 $\xrightarrow{<100\text{mA}}$ COM2	<table border="0"> <tr><td>☀</td><td>O.S.</td><td>○</td></tr> <tr><td>F.S.</td><td>☀</td><td></td></tr> </table>	☀	O.S.	○	F.S.	☀		
☀	O.S.	○							
F.S.	☀								
MIN		NO1 $\xrightarrow{I_L}$ COM1 NO2 $\xrightarrow{I_L}$ COM2	<table border="0"> <tr><td>☀</td><td>O.S.</td><td>☀</td></tr> <tr><td>F.S.</td><td>○</td><td></td></tr> </table>	☀	O.S.	☀	F.S.	○	
	☀	O.S.	☀						
F.S.	○								
	NO1 $\xrightarrow{<100\text{mA}}$ COM1 NO2 $\xrightarrow{<100\text{mA}}$ COM2	<table border="0"> <tr><td>☀</td><td>O.S.</td><td>○</td></tr> <tr><td>F.S.</td><td>☀</td><td></td></tr> </table>	☀	O.S.	○	F.S.	☀		
☀	O.S.	○							
F.S.	☀								
Instrument failure		NO1 $\xrightarrow{<100\text{mA}}$ COM1 NO2 $\xrightarrow{<100\text{mA}}$ COM2	<table border="0"> <tr><td>☀</td><td></td><td>☀</td></tr> </table>	☀		☀			
☀		☀							
Over Load ($I_L > 350\text{mA}$)		NO1 $\xrightarrow{<100\text{mA}}$ COM1	<table border="0"> <tr><td>☀</td><td>Maintain the previous state</td><td>☀</td></tr> </table>	☀	Maintain the previous state	☀			
☀	Maintain the previous state	☀							
Output2 > 350mA		NO2 $\xrightarrow{<100\text{mA}}$ COM2	<table border="0"> <tr><td>☀</td><td>Maintain the previous state</td><td>☀</td></tr> </table>	☀	Maintain the previous state	☀			
☀	Maintain the previous state	☀							
Output1 & Output2 > 350mA		NO1 $\xrightarrow{<100\text{mA}}$ COM1 NO2 $\xrightarrow{<100\text{mA}}$ COM2	<table border="0"> <tr><td>☀</td><td></td><td>☀</td></tr> </table>	☀		☀			
☀		☀							

I_L : Load current ☀ : ON ☀ : Flash ○ : OFF

TUNING AND INDICATION DETAILS

FORK TRIGGER POINT

SC14/15/16/17/24 fork trigger point is shown as below figure.

The testing medium is water(S.G.=1 g/cm³), and its trigger point is about 23mm from the fork tip. If testing medium with S.G (specific gravity) lower than 1g/cm³ (water), the trigger point would increase. Similarly, the trigger point will downward while the S.G is large than water.

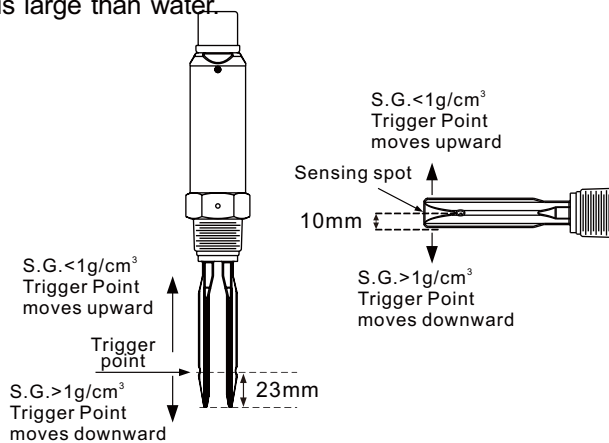

Output Status for Relay

Low (Min.) Mode: Tuning fork switch will be active after 3 seconds while power on. Relay is on NO status and red LED indication is off. When tuning fork is covered by testing medium, the vibration will stop and relay becomes NC status. Red LED indication then is on.

High(Max.) Mode: Tuning fork switch will be active after 3 seconds while the power on. Relay is on NC status and red LED indication is on. When tuning fork covered by testing medium, the vibration stops and relay becomes NO status. Red LED indication is on.

⊙ Flashing red indicates abnormal: Possible causes overloads or short-circuit load back, equipment malfunction or wear tuning fork probe.

	Min. Mode		Max. Mode		
Level					Instrument failure
Contactless electronic switch	 Switch open	 Switch closed	 Switch closed	 Switch open	 Switch open
Red LED					

It represents Blinking

MAGNETIC TEST

After the switch is installed and powered, magnetic test function can be performed accordingly. The testing point is marked on the housing label. User holds the magnet and moves it close to testing point, the output status will switch from NO. to NC. or NC to NO. and red LED would switch ON or OFF while fork continues to vibrate. When magnet is pulled away from the testing point, the output status and red LED would return as default while fork continues to vibrate. The purpose of testing is to confirm the wiring and functioning are correct.

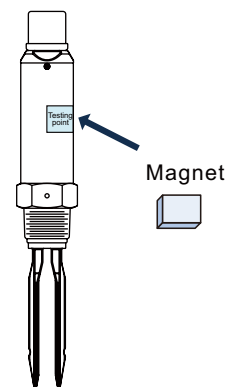

Output Status for PNP / NPN Transistor

Low(Min.) Mode : Tuning fork switch will be active after 3 seconds while power on. Output transistor is on NO status and red LED indication is off. When tuning fork covered by testing medium, vibration will stop and output transistor becomes NC status. Red LED indication is on.

High(Max.) Mode: Tuning fork switch will be active after 3 seconds while power on. Output transistor is on NC status and red LED indication is on. When tuning fork covered by testing medium, vibration will stop and output transistor becomes NO status. Red LED indication is off.

⊙ Flashing red indicates abnormal: Possible causes overloads or short-circuit load back, equipment malfunction or wear tuning fork probe.

	Min. Mode		Max. Mode		
Level					Instrument failure
PNP/ NPN Output	 Switch open	 Switch closed	 Switch closed	 Switch open	 Switch open
Red LED					

It represents Blinking

DESCRIPTION OF FEATURES (SC35)

PANEL INTRODUCTION

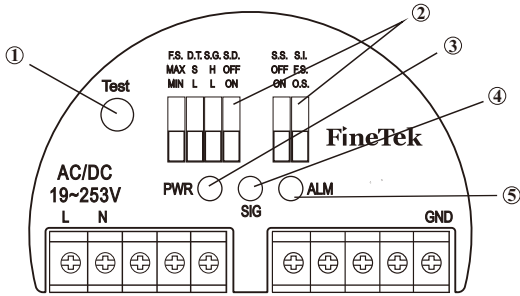

- ①: Test button
- ②: Function adjustment button
- ③: Power indicator
- ④: Status indicator
- ⑤: Alarm indicator

Abbreviation	Function	Option Description	Remarks
Test	Test button	Reverse the signal output	It is for the test after the installation is completed.
F.S.	Fail-Safe	MAX: High MIN: Low	It is for the high and low Fail-Safe mode.
D.T.	Delay Time	S: General setting L: Delay for 5 seconds	Covered by material: 0.5s Not covered by material: 150°C: ≤1.5s 230°C/280°C: ≤2s Switch to L to set it at 5 seconds for either covered or not covered by material.
S.G.	Specific Gravity	H: ≥0.05 g/cm ³ L: ≥0.01 g/cm ³	The switch to set the material density.
S.D.	Self Diagnosis	OFF: Disabled ON: Enabled	Detect the wear of the tuning fork or the viscous material and control the ON/OFF of the alarm indicator
S.S.	Super Switch	OFF: Disabled ON: Enabled	Switch the second set of output switch to the alarm indicator of the wear of the tuning fork or the viscous material for output
S.I.	Signal Indication	F.S.: Fail-Safe mode O.S.: Output mode	Turn ON/OFF the yellow indicator based on the output status or the fail-safe status.

SEDIMENT DETECTION

- It is only used to detect the sediment under the water, but can't be used for the level detection of the liquid or the doped liquid.
- S.G. (Specific Gravity) shall be adjusted to H position.
- S.D. (Self Diagnosis) shall be switched to OFF position.
- SC352 cable type is inapplicable to this working environment

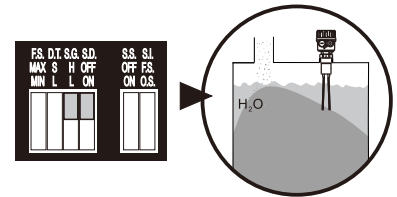

ENVIRONMENT/PROCESS TEMPERATURE LIMITATION

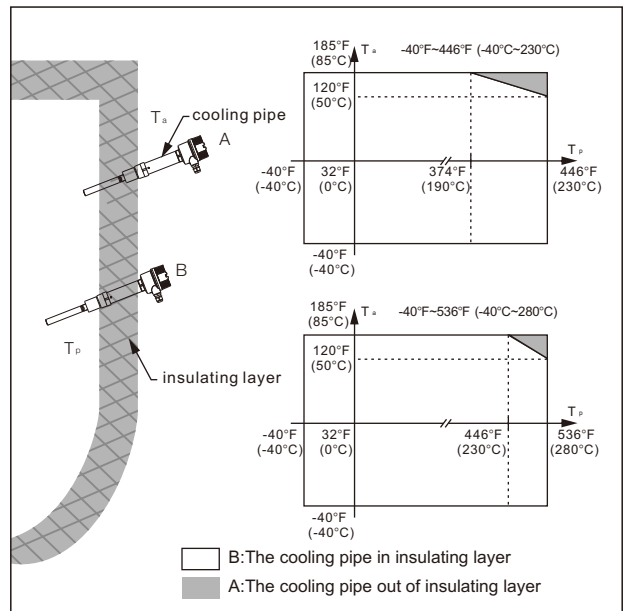
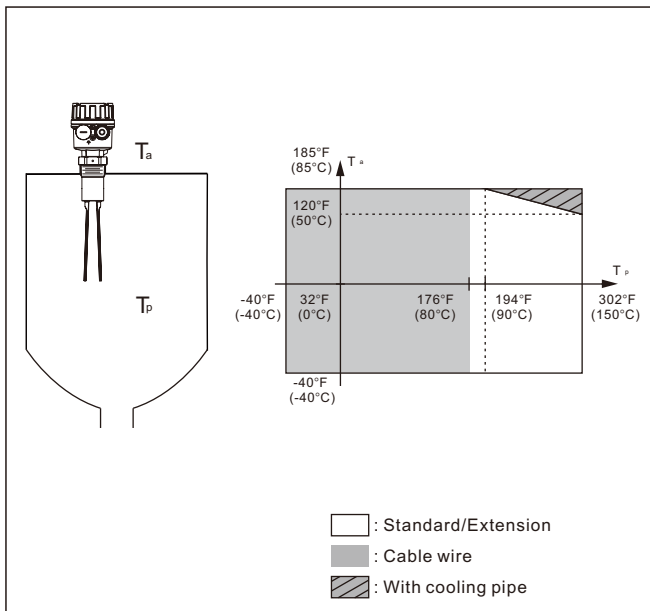

- ※ ETFE coating: T_p max. = 150°C
- ※ PTFE coating: T_p max. = 230°C

DESCRIPTION OF FEATURES (SC38 & SC39)

PANEL INTRODUCTION

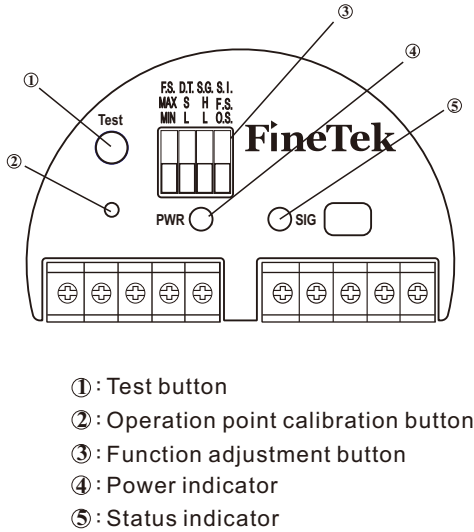

Abbreviation	Function	Option Description	Remarks
Test	Test button	Reverse the signal output	It is for the test after the installation is completed.
F.S.	Fail-Safe	MAX: High MIN: Low	It is for the high and low Fail-Safe mode.
D.T.	Delay Time	S: General setting L: Delay for 5 seconds	Covered by material: Approx. 0.5s Not covered by material: Approx. 1s Switch to L to set it at 5 seconds for either covered or not covered by material.
S.G.	Specific Gravity	H: $\geq 0.7 \text{ g/cm}^3$ L: $\geq 0.5 \text{ g/cm}^3$	The switch to set the material density.
S.I.	Signal Indication	F.S.: Fail-Safe mode O.S.: Output mode	Turn ON/OFF the yellow indicator based on the output status or the fail-safe status.

DESCRIPTION OF THE TEST BUTTON

This button is mainly provided for the user to check whether the output operation works normally after the installation is completed. When the button is pressed, the output current (8mA \leftrightarrow 16mA) and indicator (ON \leftrightarrow OFF) will be reversed. Once the button is released, it will recover the original status.

FUNCTION OF CUSTOMIZED OPERATION POINT POSITION

SC38 & SC39 provides the function of customizing the operation point position according to what is required by the user.

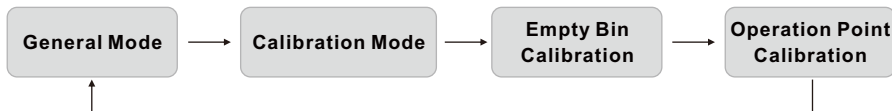

Settings

1. Keep pressing “Calibration Button” for 3 seconds. When the red and green LED indicators flash in turn every 0.5 second, it enters the calibration mode. Press the calibration button again to enter the Empty Bin Calibration mode.

[Empty Bin Calibration]

2. Calibration status: The red LED indicator flashes every 0.5 second, and the output current switches to operate every 0.5 second (8 \leftrightarrow 16mA).

3. This mode is to calibrate the vibration frequency of the tuning fork in the air. Thus, it shall press “Calibration Button” when the tuning fork doesn’t sense any material. In this case, it will write the vibration frequency in the air, and enter the operation point calibration mode.

[Operation Point Calibration]

1. Calibration status: The red LED indicator flashes every 0.25 second, and the output current switches to operate every 0.25 second (8 \leftrightarrow 16mA).

2. Cover the material to the desired operating point position under this mode, and then press “Calibration Button”. It will be adjusted to the corresponding operating point position according to the H/L setting of the S.G.

DESCRIPTION OF FEATURES (SC38 & SC39)

FORK TRIGGER POINT

The position of the SC38 & SC39 fork trigger point depends on the mounting position as shown in the figure below: (When the testing medium is water, S.G.=1 g/cm³, temperature is 23°C, and working pressure is 0 Bar). If the testing medium has an S.G lower than 1g/cm³, the trigger point would rise. Similarly, the trigger point will move downward while the S.G is greater than water. The moving distance is subject to the S.G.

※Operating point position: ◀

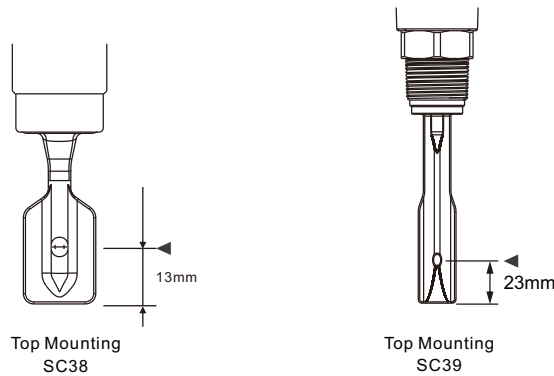

ENVIRONMENT AND PROCESS TEMPERATURE LIMITATION

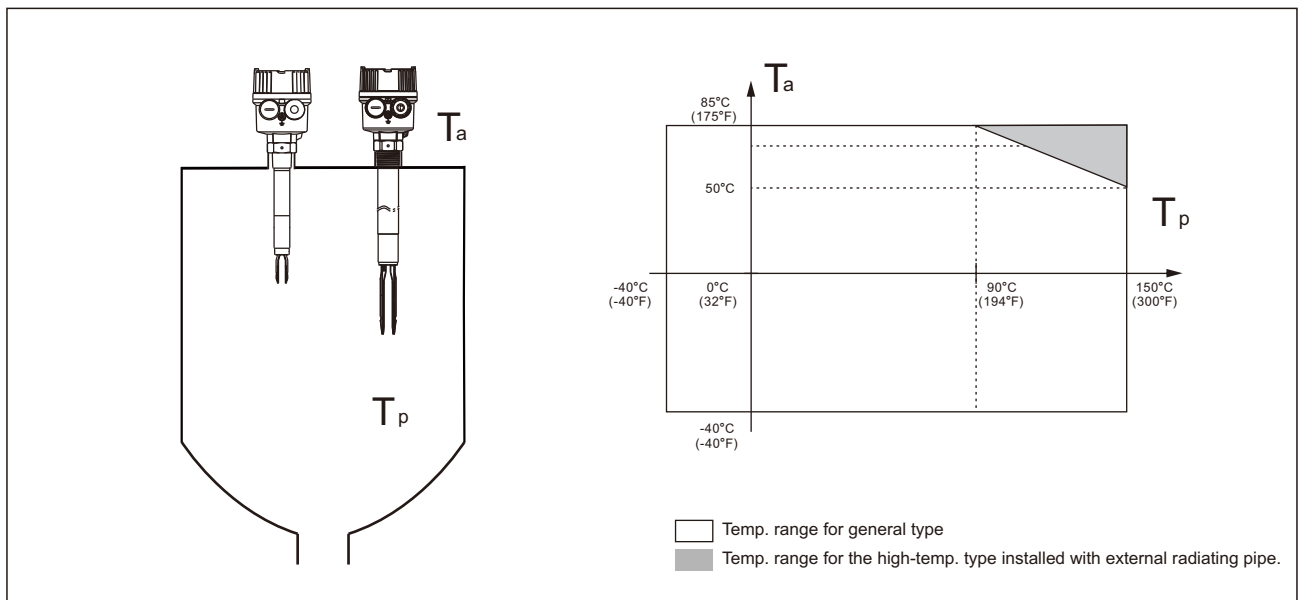

MODEL NUMBER / ORDER CODE COMPARISON TABLE

Model Number	Order Code
SC1400	SCX10000-AAB
SC1410	SCX10000-CAB
SC1420	SCX10000-BAB
SC1540	SCX10000-EAB
SC1600	SCX10300-GAB
SC1740	SCX1001C-AAB
SC1741	SCX1001C-CAB

SC2400	SCX2□□00-□B
SC2410	SCX2□□00-□B
SC2800	SCX2□□00-□A
SC2810	SCX2□□00-□A

SC350	SCX3□□□□-EC(HC,JC)
SC351	SCX3□□□□-FC(IC,KC)
SC352	SCX3□□□□-DC
SC380	SCX3□□□□-AA(EA)
SC381	SCX3□□□□-BA(FA)
SC382	SCX3□□□□-CA(GA)
SC390	SCX3□□□□-AB(EB)
SC391	SCX3□□□□-BB(FB)

ORDER INFORMATION

SCX1 ⁰⁵ ⁰⁶ ⁰⁷ ⁰⁸ ⁰⁹ - ¹² ¹³ ¹⁴ ¹⁵ ¹⁶ ¹⁷ ¹⁸ ¹⁹ ²⁰ ²¹ ²² ²³ ²⁴ ²⁵ ²⁶ A B

05 06 Model

- 00: Standard
- 03: Sanitary

07 08 Certification

- 00: None
- 1C: ATEX-Exd
- 7C: NEPSI-Exd
- 5C: TS

09 Construction

- | | |
|--------------------|------------------------------|
| A: Standard | E: Anti-Corrosion probe type |
| B: Extended type | F: Anti-Corrosion probe type |
| C: Lengthened type | G: Sanitary joint type |
| D: Cable type | |

12 Power supply

- A: 20~250Vac/Vdc, 50/60Hz ; Relay O/P-UL Type
- B: 20~250Vac/Vdc, 50/60Hz ; SSR(MOSFET)-UL Type
- C: 20~250Vac/Vdc, 50/60Hz ; Relay O/P - Euro Type
- D: 20~250Vac/Vdc, 50/60Hz ; SSR(MOSFET) - Euro Type
- E: 20~250Vac/Vdc, 50/60Hz ; Relay O/P*2 - Euro Type
- F: 20~250Vac/Vdc, 50/60Hz ; SSR(MOSFET)*2 - Euro Type

(Next page)

Connection

13 14

- Flange
- AK: JIS-FF
- AN: ANSI-RF
- AS: DIN-FF
- AI: 3A

15 16

- A8: 1"
- A9: 1-1/4"
- B1: 1-1/2"
- B2: 2"
- B4: 2-1/2"
- B5: 3"
- B7: 4"
- D8: DN25
- E1: DN40

17 18

- 01: PT male
- 03: PF male
- 07: NPT male
- 40: 5 kg/cm²
- 42: 10 kg/cm²
- 48: 150 Lbs
- 49: 300 Lbs
- 57: PN10
- 58: PN16

Thread

- AA: JIS
- AC: ANSI

ORDER INFORMATION



⑤
⑥
⑦
⑧
⑨
⑫
⑬
⑭
⑮
⑯
⑰
⑱
⑲
⑳
㉑
㉒
㉓
㉔
㉕
㉖

SCX1 - **AB**

⑲ ⑳ Probe material

- MA: SUS304
- MB: SUS316
- MC: SUS316L

㉑ ㉒ Insulated material

- 00: None
- 14: PFA
- 34: ECTFE

㉓ ㉔ ㉕ ㉖ Length

Code	Probe Length
0001~9999	0001~9999mm

TX10 ISOLATED SAFETY BARRIER

OPERATING PRINCIPLE

Isolated safety barrier provides power supply to transmitters located in hazardous zone and transmit isolated supply current signal to safe zone. Max. input 0~20mA which can be transformed to different analog outputs, such as 0~20mA / 4~20mA / 0~5V / 0~10V.

FEATURES

- 1 current input port to connect with continuous current or current output products. Applicable for use in hazardous zone.
- 3 output ports - relay output, current output, and RS-485.
- LED indicator, user friendly.
- DIP switch for function selection.
- In house programming per customers' criteria.
- Self-test function for system function monitoring.
- Setting relay output as alarm for optional external sensing unit connection.
- Optional RS-485 interface enables easy system configuration & supply current data retrieve.
- Product design complies with explosion proof standard.
- 2 dual-color LEDs
 - ▶ PWR LED: Green - Normal
Red - Abnormal
 - ▶ OUT/CHK LED: Yellow - Relay activated
Red (Flash) - Input current abnormal

SCHEMATIC DIAGRAM

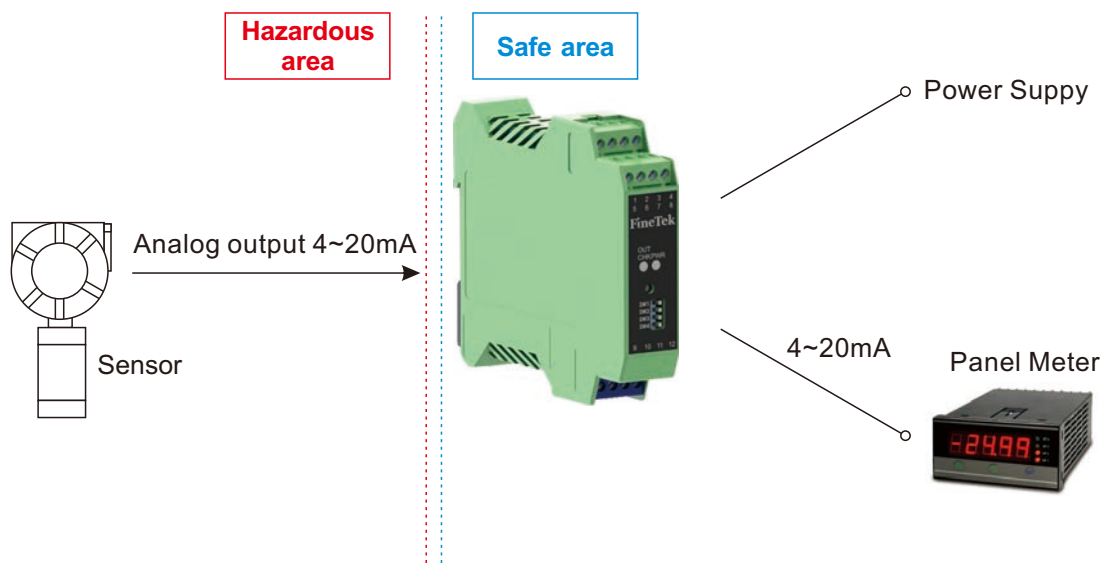

STANDARD SPECIFICATIONS

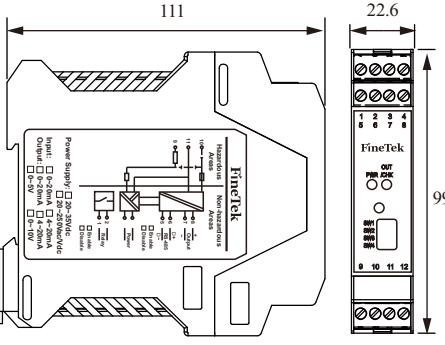
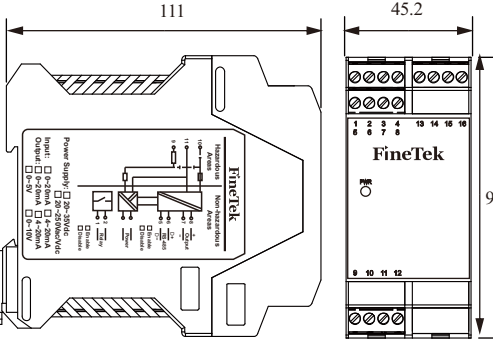
<p>Dimensions (Unit:mm)</p>		
<p>Model No.</p>	<p>TX100R</p>	<p>TX101F</p>
<p>Supply voltage</p>	<p>20~35 Vdc</p>	<p>20~250 Vdc/Vac, 50/60 Hz</p>
<p>Power supply protection</p>	<p>Reversed power supply protection</p>	<p>Non-directional input</p>
<p>Power consumption</p>	<p>< 100 mA @24 V, Load 20mA</p>	<p>< 200 mA @24 V, Load 20mA</p>
<p>Hazardous Area</p>		
<p>Current input</p>	<p>0~20/4~20</p>	
<p>Open-circuit voltage</p>	<p>< 28 Vdc</p>	
<p>Distribution voltage</p>	<p>> 15 Vdc (Load 20 mA)</p>	
<p>Safe Area</p>		
<p>Output</p>	<p>Current: 0~20/4~20 mA Load impedance: <550 ohm or Voltage: 0~5/0~10 V Load impedance: <20k ohm</p>	
<p>Reaction time</p>	<p>5 ms (Reach 90% of the final value)</p>	
<p>Transmission precision</p>	<p>0.1 % F.S.,0.5%@<0.3V (20°C)</p>	
<p>Temp. coefficient</p>	<p>< 100 ppm/°C</p>	
<p>Insulation strength</p>	<p>2500 Vac : Leakage current <1 mA ; 1min 1. Intrinsically safe end and non-intrinsically safe end 2. Non-intrinsically safe power supply end and output end</p>	
<p>Operating temp. in ambient air</p>	<p>-20~60 °C</p>	
<p>Application environment</p>	<p>Area 0 , Area 1, Area 2, IIA 、 IIB 、 IIC T4~T6</p>	
<p>Field equipment</p>	<p>1. Two-wire sensor 2. Three-wire sensor 3. Current output sensor</p>	

MODEL NUMBER / ORDER CODE COMPARISON TABLE

ORDERING INFORMATION

Model Number	Order Code
TX100R	TXX1017BB
TX101F	TXX1007BC

TXX 1 ⁰⁵ ⁰⁶ ⁰⁷ ⁰⁸ - ⁰⁹ ¹⁰ ¹¹ ¹² ¹³

⁰⁵ ⁰⁶ Model

- 00: Standard(W45.2×H113.6×D99)
- 01: Economic(W22.6×H113.6×D99)

⁰⁷ ⁰⁸ Certification

- 00: None
- 7B: NEPSI-Exia

⁰⁹ Power supply

- B: DC 20~35 Vdc
- C: AC 20~250 Vac

¹⁰ Input

- A: 4~20mA
- B: 0~20mA

¹¹ Output 1

- A: 4~20 mA
- B: 0~20 mA
- C: 0~5 V
- D: 0~10 V

¹² Output 2

- 0: None
- A: RS485

¹³ Output 3

- 0: None
- C: Relay

Sensorsystem®
Innovative Sensors Controls for Automation

Sensorsystem S.r.l.

via Amendola, 35/B

20037 Paderno Dugnano (Mi)

Tel. 02.9185051 Fax 02.99046839

www.sensorsystem.it info@sensorsystem.it