



Optical Level Switch



Sensorsystem®
Innovative Sensors & Controls for Automation

INTRODUCTION

WORKING PRINCIPLE

The optical liquid level switch uses the principle of total reflection in a prism. Reflection or penetration, is the basis of the level alarm output. When the sensor is surrounded by air, the angle of incidence is greater than the critical angle and thus total reflection occurs.

Totally reflected light will be transmitted to the receiver. Conversely, when the sensor is surrounded by liquid, due to the refractive index of the liquid and the sensor tip material, almost all light will penetrate the front of the sensor. Using this principle, the optical liquid level switch design is based on light. The receiver can detect and determine a light reflected or penetrated state, and determines the circuit output.

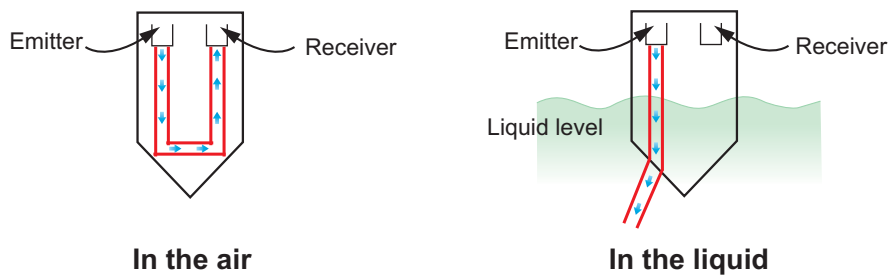

FEATURES

- Simple, compact, and robust
- No moving parts
- Built-in, solid-state electronics
- Easily removed, cleaned, and reinstalled
- LED switch indication

APPLICATIONS

- Pharmaceutical systems
- Air conditioning systems
- Industrial compressors
- Food and beverage systems
- Hydraulic reservoirs
- Machine tools
- Liquid holding tanks
- Processing and packaging equipment
- Heavy duty automotive
- Sumps

SD20 SPECIFICATION

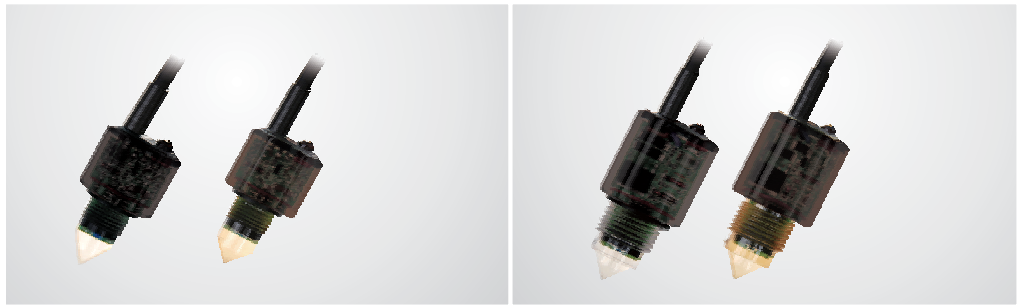

Housing material	PC / PES	
Tip material	PC / PES	
Supply voltage	10~28 Vdc	
Load current	≤100 mA	
Current consumption	<15 mA	
Output mode	NPN / PNP	
Output function	NO / NC	
Electrical protection	reverse polarity protection, short circuit protection	
Ambient temp.	-10~80 °C	
Operation temp.	-10~125 °C	
Process pressure	<10 kg / cm ²	
IP rating	IP 67	
Indicator light	Red LED	
Cable specifications	PVC, 24 AWG, L=2 m, 3C (blue, green, black, and brown)	
Installation torque	50 kgf-cm	
Thread options	PT / PF / NPT	
Connection size	M12x1.0	3/8"
UL File Number	SA44153	
Dimension (Unit: mm)		

※PES(polyethersulfone) is similar PSU(polysulfone), but its heat resistance, strength, and stiffness is better.

SD20 SPECIFICATION



Housing material	SUS304 / SUS316	
Tip material	PES	
Supply voltage	10~28 Vdc	
Load current	≤100 mA	
Current consumption	<15 mA	
Output mode	NPN / P NP	
Output function	NO / NC	
Electrical protection	reverse polarity protection, short circuit protection	
Ambient temp.	-10~80 °C	
Operation temp.	-10~125 °C	
Process pressure	<40 kg / cm ²	
IP rating	IP 67	
Indicator light	Red LED	N/A
Cable specifications	PVC, 24 AWG, L=2 m, 3C (blue, green, black, and brown)	N/A
Installation torque	100 kgf-cm	
Thread options	PT /PF / NPT	PF
Connection size	3/8"	1/2"
UL File Number	SA44153	
Dimension (Unit : mm)		

SD20 SERIES

FEATURE

- NPN, PNP open collector output to energize relay or PLC
- Housing material of PC, PES, SUS304, SUS316 for applicable in water, oil, liquid solution, liquor, alcohol, organic solvent...etc.
- PC, PES for acidity and alkaline
- Over-current and reverse polarity protected
- LED status indication

WIRING

- Lead wire

NPN output

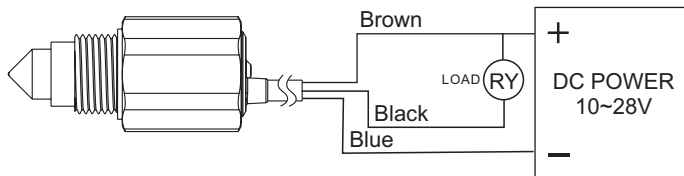

PNP output

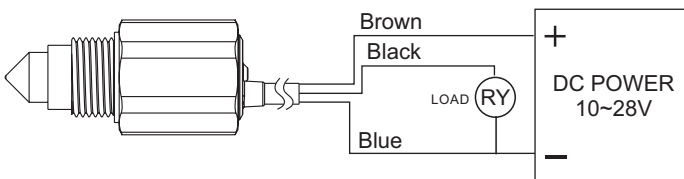

- M12x1 connection

NPN output

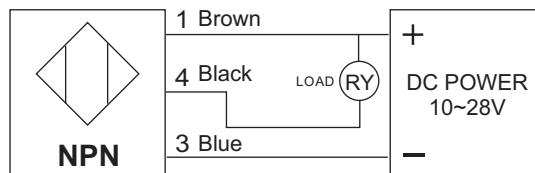

PNP output

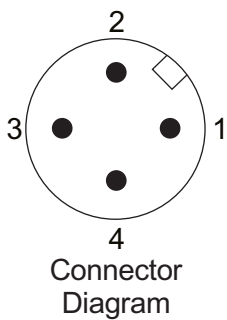
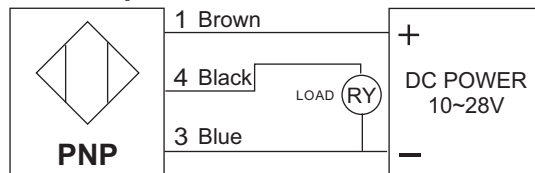

MODEL NUMBER / ORDER CODE COMPARISON TABLE



Model Number	Order Code
SD20P	SDX1003A-□□□□□11
SD20G	SDX1003A-□□□□□35
SD204	SDX1003A-□□□□□MA
SD206	SDX1003A-□□□□□MB
SD215	SDX2003A-□□□□□MA
SD217	SDX2003A-□□□□□MB
SD220	SDX4003A

ORDER INFORMATION

SDX1 0 0 07 08 - 09 10 11 12 13 14 15 16 17 18 19 20 21 22 23 24

07 08 Certification

00: None
3A: UL

Connection

09 10

AA: JIS
AC: ANSI

11 12

A4: 3/8"
A5: 1/2"
I 3: M12

13 14

01: PT male (only SUS304,316)
03: PF male
07: NPT male
17: G NPT(only SUS304,316)
78: M12X10(only PC,PES)

※SD20 series, choose 3/8" PT male connector, no UL certification

15 16 Body and Probe material

MA: SUS 304 + PES
MB: SUS 316 + PES
11: PC(Only PC body material)
35: PES

17 Power supply

A: 10~28Vdc

18 Output

P: PNP
N: NPN

19 Wiring

A: Cable(UL)
B: M12(only 1/2"G)
D: Cable + rub

20 Contact

A: NO
B: BC

22 23 24 25 Length

Code	Cable Length
2000	Standard 2000mm
0000	None

SD21 SPECIFICATION



Model	Cable type	M12 connection type
Tip material	Glass	
Body material	SUS304 / SUS316	
Supply voltage	10 ~ 28 Vdc	
Load current	≤ 200 mA	
Current consumption	< 25 mA	
Output mode	NPN / PNP	
Output function	NO + NC	
Electrical protection	reverse polarity protection, short circuit protection	
Delay time	5 sec ± 1 sec (optional)	
Ambient temp.	-20~80 °C	
Operating temp.	-20~100 °C	
Working pressure	< 60 bar	
Anti-ambient light interference	< 500 lux	
IP rating	IP 67	
Indicator light	Red LED	N/A
Cable specifications	Silicone rubber jacket, 24 AWG, L=2 m, 4C (blue, green, black, and brown)	N/A
Installation torque	75 kgf-cm	
Thread options	PT / PF / NPT	
Connection size	3/8" / 1/2"	
UL File Number	SA44153	
Dimension (Unit: mm)		

SD21 SERIES

FEATURES

- NPN / PNP output selection can be connected to the relay or PLC.
- This product provides both NO and NC output for selection.
- Products made of glass and SUS 304/316, diesel fuel, waste water, aqueous solution, alcoholic solution.
- Includes power polarity and over current protection.
- LED indicates contact status.
- There are general cloudy and turbidity for option.
- You can measure turbid solutions.
- Also output a delayed-type output can be selected.

WIRING

Type	High position delay		Low position delay		Standard type	
Position						
LED						
Green wire						
Black wire						

Output function	Wire color	Wiring		
NO	Green			
BC	Black			

ORDER INFORMATION

Glass Probe

SDX 2 0 0 ⑦⑧ ⑨⑩ ⑪⑫ ⑬⑭ ⑮⑯ ⑰⑱ ⑲⑳ ㉑㉒ ㉓㉔ ㉕

⑦⑧ Certification

00: None
3A: UL

Connection

⑨⑩

AA: JIS
AC: ANSI

⑪⑫

A4: 3/8"
A5: 1/2"

⑬⑭

01: PT male
03: PF male
07: NPT male

⑮⑯ Body and Probe material

MA: glass+SUS304
MB: glass+SUS316

⑰ Power supply

A: 10~28Vdc

⑱ Output

P: PNP
N: NPN

⑲ Wiring

A: Cable(UL)
B: M12(only 1/2"G)
D: Cable + rub

⑳ Delay time

A: No delay time
B: High delay of 5 seconds
C: Low delay of 5 seconds

㉑ Turbidity

A: Standard
B: Turbid

㉒㉓㉔㉕ Length

Code	Cable Length
2000	Standard 2000mm
0000	None

SD22 SPECIFICATION



Model	Typical	Motor power detection
Tip material	Glass	
	Zinc-plated steel / SUS304 / SUS316	
Body material	PA66 glass fiber reinforced	
Supply voltage	AC 50/60 Hz 115 V ±20%	
	AC 50/60 Hz 230 V ±20%	
Relay specifications	AC 240 V, 2.5 A, C300	
Switch life time	10 ⁵ switching cycles	
Ambient temp.	-40 ~ 85 °C	
Operating temp.	-40 ~ 100 °C or 120°C (<1h)	
Delay time (customization)	-Relay ON after applying the supply voltage (3s ± 1s) -Relay OFF after level continue missing (5s ± 1s)	-Relay ON after applying the supply voltage (3s ± 1s) -Level monitoring after relay ON (30s ± 1s) -Relay OFF after level continue missing (5s ± 1s)
	Yes	
process pressure	65 bar	
Anti-ambient light interference	< 500 lux	
IP rating	IP 65	
Cable specifications	PVC, 18 AWG, L=1m, 5C color coded	PVC, 18 AWG, L=1m, 6C color coded
Installation torque	75 Nm	
Connecting screw	1/2" (PT, PF, NPT) / M20X1.5 mm	
Tip part weight	around 51 g	
Body part weight	around 167 g	
UL File Number	SA44153	
Dimension (Unit: mm)		

SD22 SERIES

APPLICATION

- SD22 uses optical technology to achieve level monitoring and is durable to shocks in the environment.
- Uniquely different design (2 separate parts) compared to the traditional optical switch model.
- SD 22's switch body can be removed while the tip remains installed on tank. No tank drainage or leakage required when removing switch.
- Intelligent process control for not only do liquid level detection, but also with other sensors connected in series so that the full system has protection.
- According to customer demand, adjustable delay time length.
- Self-test function.
- The device is able to detect whether sensor body and tip are installed incorrectly.
- The LED indicator is readily apparent users to see.
- Quick coupling provide faster installation and reliable fix.

	Color	Status	LED lights
Power	Green	Supply in	ON
Status	Red	High level	OFF
		Low level	ON
		Error	Blinking

WORKING FLOW

◆ SDB-B0□T□ (5 wire, typical)

1. Three seconds after the power is turned on, the relay is on.
2. Liquid level detection, level required sustained low 5 seconds, the relay OFF and status light turns on.
3. Liquid level detection, level requires continuous contact for five seconds, the relay turns on, the status light turns off.

WIRING DIAGRAM

◆ SDB-B0□T□ (5 wire, typical)

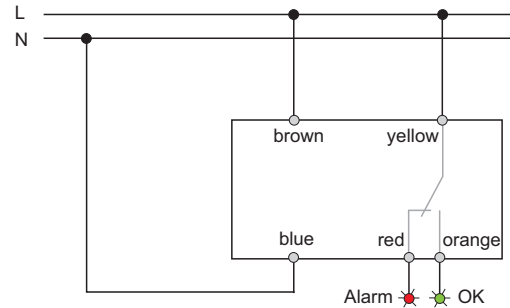

◆ SDB-B0□M□ (6 wire, motor power detection)

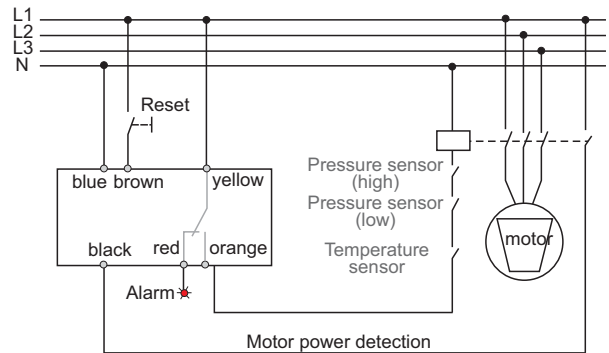

◆ SDB-B0□M□ (6 wire, motor power detection)

1. Three seconds after the power is turned on, the relay turns ON.
2. Detects the motor power supply is normal after a delay of 30 seconds to enter the liquid level detection state.
3. Liquid level detection, level required sustained low for 5 seconds, the relay turns off and status light is turned on, enters the Locked state.
4. Need to restart the power to cancel the alarm state and re-start the process.

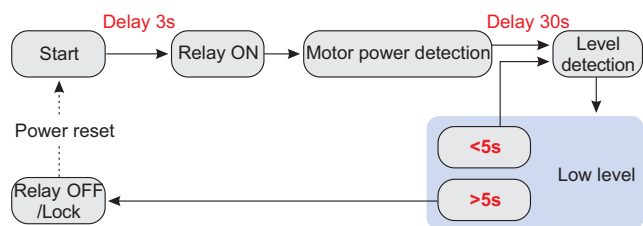
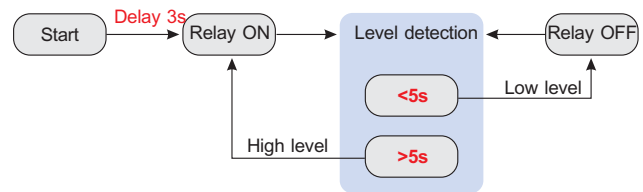

ORDER INFORMATION

Refrigeration-glass Probe

SDX4 0 0 07 08 - 09 10 11 12 13 14 15 16 17 18 19 20 21 22 23 24

⑦⑧ Certification

00: None
3A: UL

Connection

⑨⑩

AA: JIS
AC: ANSI

⑪⑫

A5: 1/2"
J2: M20

⑬⑭

01: PT male
03: PF male
07: NPT male
B2: M12X1.5

⑮⑯ Body and Probe material

MA: glass+SUS304
MB: glass+SUS316
ME: glass+SUS Zinc +Plated steel

⑰ Power supply

A: Vac 115V
B: Vac 230V

⑱ Output

R: Relay

⑲ Function

T: Typical (5 wire)
M: Motor power detection (6 wire)

⑳ Connector of tip and body

A: Crew joint (F)
B: Quick coupling (F)
C: Crew joint (Glass welding)

㉑㉒㉓㉔ Length

Code	Cable Length
1000	Standard 1000mm

ORDER INFORMATION

Tip

Order code	Connector of tip and body	Connector type	Power supply
Options	A: Crew joint (F) N: Quick coupling (F)	T: Typical (5 wire) M: Motor power detection (6 wire)	AC115V ± 20% AC230V ± 20%
SDXAA1X-0016	A: Crew joint (F)	T: Typical (5 wire)	AC230V ± 20%
SDXAA1X-0009	A: Crew joint (F)	M: Motor power detection (6 wire)	AC115V ± 20%
SDXAA1X-0010	A: Crew joint (F)	M: Motor power detection (6 wire)	AC230V ± 20%
SDXAA1X-0013	N: Quick coupling (F)	T: Typical (5 wire)	AC115V ± 20%
SDXAA1X-0014	N: Quick coupling (F)	T: Typical (5 wire)	AC230V ± 20%
SDXAA1X-0011	N: Quick coupling (F)	M: Motor power detection (6 wire)	AC115V ± 20%
SDXAA1X-0012	N: Quick coupling (F)	M: Motor power detection (6 wire)	AC230V ± 20%

Body

Order code	Connector of tip and body	Connector type	Power supply
Options	A: Crew joint (F) N: Quick coupling (F)	BQ:1/2"PT BR:1/2"PF BU:1/2"NPT M2:M20X1.5	0: SUS304 6: SUS316 Z: Zinc-plated steel
SDXAM1A-MAA5030001	A: Crew joint (F)	BR:1/2"PF	0: SUS304
SDXAM1A-MAA5070001	A: Crew joint (F)	BU:1/2"NPT	0: SUS304
SDXAM1A-MPJ2820001	A: Crew joint (F)	M2:M20X1.5	Z: Zinc-plated steel
SDXAM1A-MAA5010001	N: Quick coupling (F)	BQ:1/2"PT	0: SUS304
SDXAM1A-MAA5030002	N: Quick coupling (F)	BR:1/2"PF	0: SUS304
SDXAM1A-MPA5030001	N: Quick coupling (F)	BR:1/2"PF	Z: Zinc-plated steel
SDXAM1A-MAA5070002	N: Quick coupling (F)	BU:1/2"NPT	0: SUS304

CAUTION

- Cable wiring to be done in accordance with the operating manual connection.
- SD22s parts and body part manually tightened (torque about 10Kgf-cm).
- During installation note that the cable outlet direction is downward.
- This product is not for solids in solution, solids containing adhesion of suspended or viscous liquids.
- Do not scratch the tip of sensor.
- SD21 turbid type and SD22 can measure 4000NTU standard turbidity solution.
- This product can not be used in the environment with an infrared light source.
- We recommend the following installation below. The horizontal plane parallel to the $0^{\circ} \sim 45^{\circ}$ for optimal installation angle.

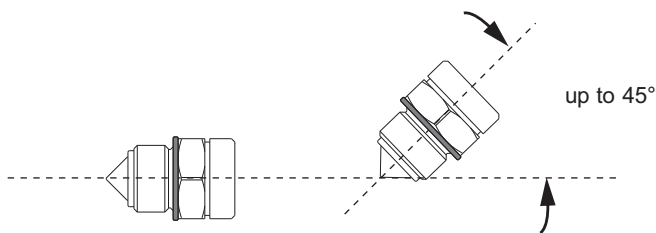

- This product can not be installed in the liquid at the flow entry point.
- Don't have any reflective surface or other interference at the front cone radius 30mm, as shown.
- The tip of optical level switches front of the sensor and the tank wall must be at least distance 30mm, as shown.

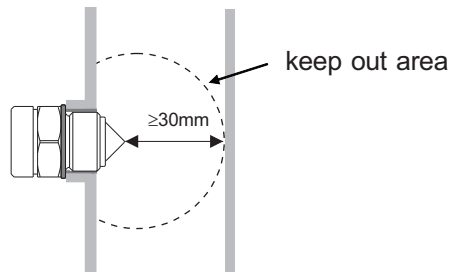

- Install the threaded sleeve photoelectric switch, the tip of switch must break the casing.

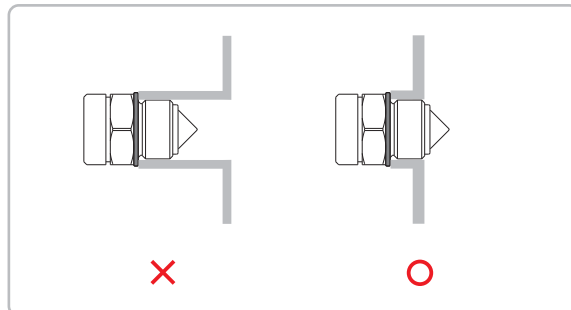

APPLICATIONS

Sea water cooling system

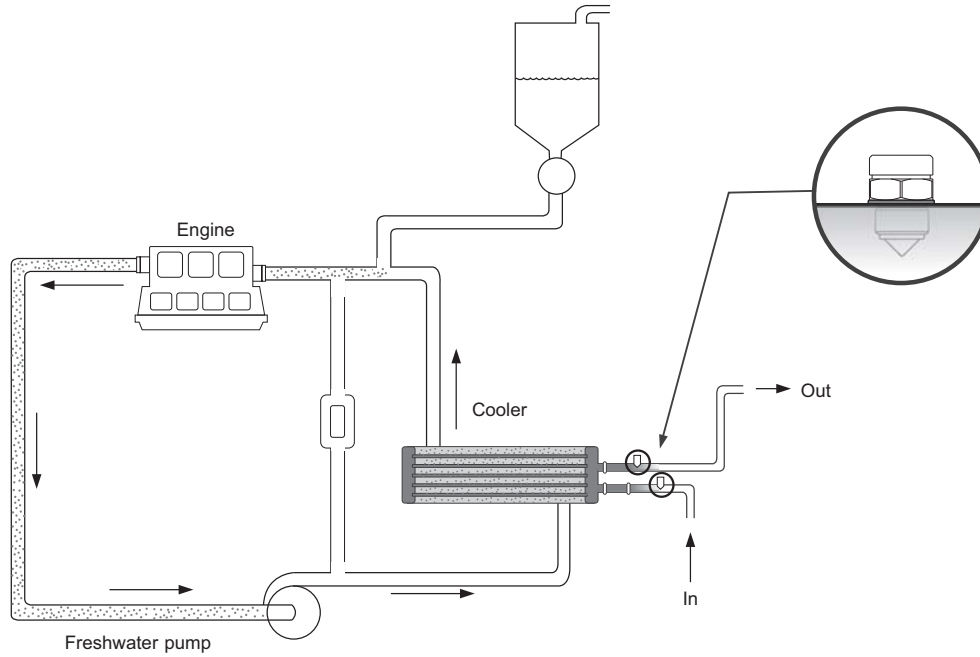

Double-wall pipe and double-wall tank leakage detection

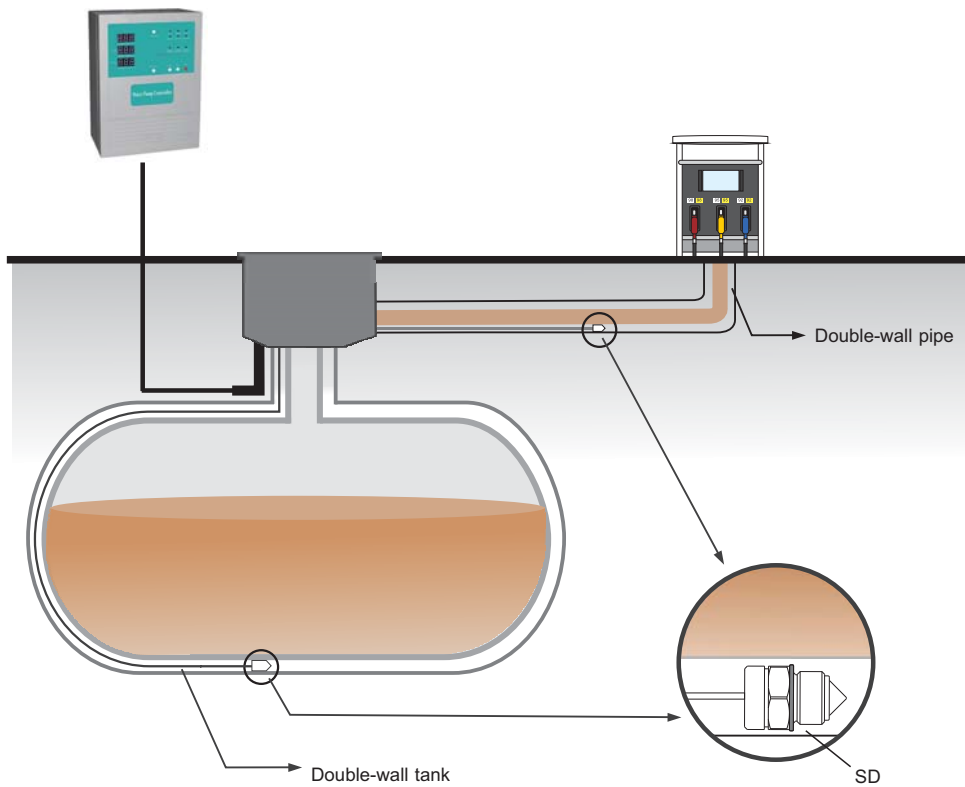

APPENDIX

M12 Cable list

Item	Part number	Connector type	Length	Temperature	IP rating	SD20	SD21
1	PC312-1231415M01	Right Angle Straight	5m	-25 ~ +100°C	IP 67 IP 68 IP 69K	V	
2	PC312-2221410501	Right Angle	5m	-25 ~ +90°C	IP67	V	V
3	PC312-1221415M01	Straight	5m	-25 ~ +90°C	IP67	V	V
4	PC312-1221422M01	Right Angle	2m	-25 ~ +80°C	IP67	V	V
5	PC312-2101422M01	Straight	2m	-25 ~ +80°C	IP67	V	V
6	PC312-2101425M01	Straight	5m	-25 ~ +80°C	IP67	V	V
7	PC312-2101421001	Straight	10m	-25 ~ +80°C	IP67	V	V

Sensorsystem®
Innovative Sensors. Controls for Automation

Sensorsystem S.r.l.

via Amendola, 35/B

20037 Paderno Dugnano (Mi)

Tel. 02.9185051 Fax 02.99046839

www.sensorsystem.it info@sensorsystem.it